



VEGETABLE PREPARATION MACHINE CA-62

High-production vegetable cutter, up to 1000 kg/h.



SALES DESCRIPTION

Two-speed motor block + high-production semi-automatic hopper.

FEATURES AND BENEFITS

A perfect cut

- ✓ High precision adjustments to obtain a uniform and excellent-quality cut.
- ✓ It can be fitted with a wide range of discs and grids of the highest cutting quality.
- ✓ Combining these accessories together to obtain more than 70 different types of cuts and grating grades.
- ✓ Head equipped with high ejector: enables a higher quantity of product to be shifted.

Built to last

- ✓ Made from stainless steel and materials of the highest quality and suitable for food contact: stainless steel motor block and hopper and food-grade aluminium head.
- ✓ High power asynchronous motor.

Maximum comfort for the user

- ✓ Ergonomic design. Maximum comfort for the user.
- ✓ Lateral product output: requires less space on the work-top and guides the product, avoiding splashes.
- ✓ The electronic command panel is very intuitive.

Maintenance, safety, hygiene

- ✓ Hopper and lid easily removable for cleaning.
- ✓ Combination of safety systems: hopper, cover, power switch.
- ✓ Appliance certified by NSF International (regulations on hygiene, cleaning and materials suitable for contact with foods).
- ✓ 100% tested.

INCLUDES

- ✓ Two-speed motor block.
- ✓ High production semi-automatic hopper.

ACCESSORIES

- Large capacity head.
- Tube head.
- Support-car.
- Discs and grids.
- Grid cleaning kit.

DYNAMIC PREPARATION
COMMERCIAL VEGETABLE PREPARATION MACHINES



VEGETABLE PREPARATION MACHINE CA-62

High-production vegetable cutter, up to 1000 kg/h.



SPECIFICATIONS

Hourly production: 500 Kg - 1000 Kg

Inlet opening: 273 cm²

Disc diameter: 205 mm

Motor speed: 365-730 rpm

Loading: 750 W

Noise level (1m.): <70 dB(A)

Background noise: 32 dB(A)

External dimensions (WxDxH)

Width: 430 mm

Depth: 420 mm

Height: 810 mm

Net weight: 29.5 Kg

Crated dimensions

480 x 480 x 740 mm

Volume Packed: 0.17 m³

Gross weight: 34 Kg.

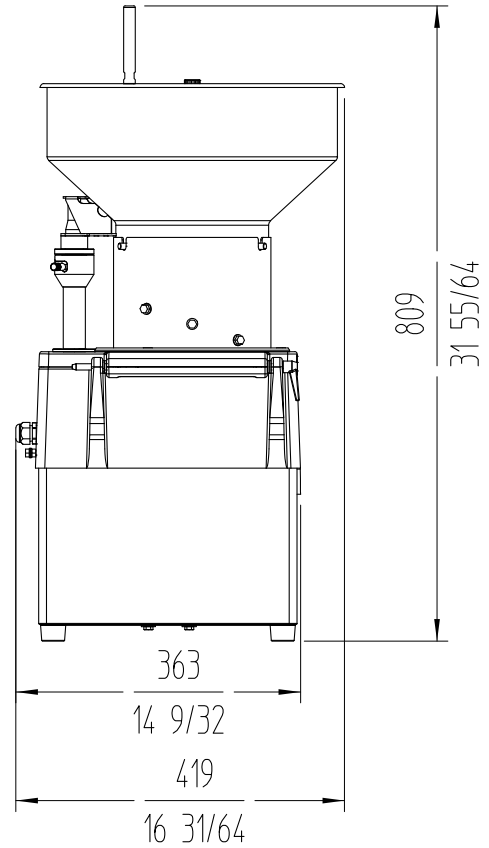
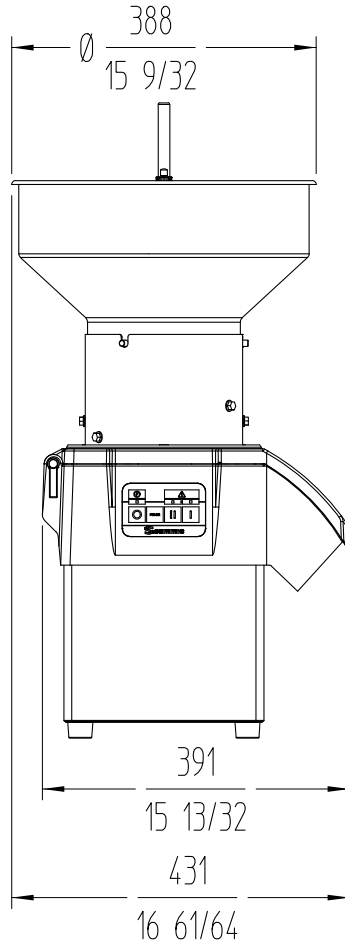

AVAILABLE MODELS

1050738 Vegetable preparation machine CA-62 400/50/3

1050740 Vegetable preparation machine CA-62 400/60/3

1050744 Vegetable preparation machine CA-62 220/60/3

DYNAMIC PREPARATION
COMMERCIAL VEGETABLE PREPARATION MACHINES

product sheet
updated 20/02/2020